

OPERATING INSTRUCTIONS

for

DynaTension[®] Meter

Model P1000
S/W version 6.01

Manufactured By:

**VITEN DYNATENSION, INC.
6503 NORTHWAY DRIVE
SPRING, TEXAS
Phone (281) 251-9788
wsarnold@earthlink.net**

Revision 29g

TABLE OF CONTENTS

		PAGE
	APPENDICES.....	ii
	WARRANTY.....	iii
1.0	INTRODUCTION.....	1
2.0	SPECIFICATIONS.....	3
3.0	PREPARING TO USE THE P1000.....	4
4.0	DETERMINING THE SPAN.....	4
4.1	SPAN LENGTH MEASUREMENT.....	4
4.2	DEALING WITH A PARTIALLY SUBMERGED SPAN.....	4
4.3	DEALING WITH TURNBUCKLES AND END FITTINGS.....	5
5.0	DETERMINING THE WEIGHT PER FOOT.....	5
6.0	COMPENSATING THE READINGS FOR MAXIMUM ACCURACY.....	6
6.1	KFACTOR FROM TABLES IN APPENDICES.....	6
6.2	MEASURING THE KFACTOR.....	7
6.3	CALCULATING THE KFACTOR.....	8
7.0	SELECTING THE MOST SUITABLE SENSOR.....	8
7.1	LONG SPANS OF LARGE CABLE OR CHAIN.....	8
7.2	MEDIUM SPANS - DIAMETERS UP TO TWO INCHES (51 MM).....	8
7.3	SHORT SPANS – DIAMETERS UP TO ¼ INCH (6 MM).....	9
8.0	KEYPAD ENTRIES.....	9
8.1	ERROR MODE CODES.....	11
9.0	POSITIONING THE SENSOR.....	11
9.1	VARI-L PROBE.....	11
9.2	EOSENS PROBE.....	12
9.2.1	MEASURING TENSION IN FILAMENT.....	12
9.2.2	MEASURING TENSION IN BELTS.....	13
9.3	ACSENS PROBE.....	13
10.0	EXCITING THE MATERIAL.....	14
10.1	LONG SPANS OF LARGE CABLES OR CHAIN.....	14
10.2	SPANS OF LARGE CABLES.....	14
10.3	LONG SPANS OF SMALL CABLES.....	14
10.4	SHORT SPANS OF SMALL CABLES.....	15
10.5	VERY LIGHT WEIGHT MATERIALS.....	15
11.0	BATTERY SUPPLY.....	15

TABLE OF CONTENTS (CONTINUED)

12.0	VERIFYING INSTRUMENT ACCURACY.....	16
13.0	MAKING A TENSION MEASUREMENT.....	16
14.0	MEASURING FREQUENCY.....	17
15.0	EXTENDING THE INSTRUMENT RANGE.....	17
16.0	TROUBLE-SHOOTING THE INSTRUMENT.....	18

APPENDICES

APPENDIX A	CABLE WEIGHT/FOOT TABLES	19
APPENDIX B	KFACTOR COMPENSATION TABLES.....	24
APPENDIX C	TURNBUCKLE DATA.....	27
APPENDIX D	ALLOWABLE LENGTH TO DIAMETER RATIO.....	30
APPENDIX E	EXCITATION FORCE VS LENGTH AND TENSION.....	35
APPENDIX F	ESTABLISHING BRIDGEPOINTS.....	40

WARRANTY: Viten DynaTension, Inc, warrants the Model P1000 *DYNATENSION*[®] instrument against defects in materials, components and workmanship for one year from date of shipment. An instrument determined to be defective in the warranty period will be repaired or replaced by Viten, at its option, at the original F.O.B. point. This warranty does not extend to damage in shipment, misuse, batteries, or other failure not caused by original defects in materials, components or workmanship.

1.0 INTRODUCTION

DynaTension[®] is a precision instrument which measures tension in wire rope, cable, filament, belt, webbing and pre-stressed strand. Its unique non-contact operating principle completely eliminates in-line installation, cable or rope wear. Exceptional accuracy and reliability are inherent in its operational technique.

DynaTension[®] achieves these desirable attributes as a consequence of the physical principle on which the instrument is based. A uniform hinged beam subjected to an axial tension T has a natural frequency of:

$$\Omega_n = \left[\left(\frac{N\pi}{L} \right)^2 \frac{T}{M} + \left(\frac{N\pi}{L} \right)^4 \frac{EI}{M} \right]^{\frac{1}{2}}$$

Ω = Radian frequency - Radian frequency is $2\pi f$, where f is the frequency in Hertz, or cycles per second.

Ω_n = The n th harmonic, i.e., 1, 2, 3 n of the radian frequency

$\frac{N\pi}{L}$ = Any integral multiple of pi, or 3.1416, divided by span length in feet

$\frac{T}{M}$ = Tension divided by mass per unit length, i.e., slugs per foot or kilograms per meter

$\frac{EI}{M}$ = (E) modulus of elasticity multiplied by (I) area moment of inertia, divided by (M) mass per unit length

Mass per unit length is the same as weight per foot divided by "g". "G" is gravity constant which is 32.2 ft per sec per sec, or ft per second squared. In the metric system, mass per unit length is in kilograms per meter.

DynaTension[®] senses the vibration frequency of a length of the cable (L) between two bridge points and calculates the tension (T) using the **fundamental wave** in the equation on the previous page. See waveforms below.

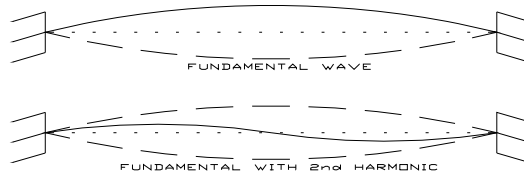

Sensing the cable vibration is done with a proximity sensor; and physical contact is avoided, except for "strumming" the cable. This is done by a light, sharp, blow similar to the tap of a piano key, or by plucking the cable as a guitar string is plucked (See section 10.0). Alternatively, a small contact sensor may be attached to the cable in those cases where it is more convenient.

The second term in the bracketed expression is a vibrating rod term that is independent of tension. In most applications, L is chosen as the distance between two existing sheaves and is usually sufficiently long for the rod term to be negligibly small. Nevertheless, backing out that "correction" term results in the potential to measure T quite accurately, provided the cable mass and length are accurately known.

The portable tension meter, Model P1000, computes and displays either English or metric units. The default mode is the English system. In this mode, weight per unit length is entered in pounds per foot, length is entered in inches and tension is displayed in pounds.

A two key sequence changes the mode to metric. In this mode, mass per unit length is entered in kg per meter. Length is entered in centimeters and tension is displayed in NEWTONS. The decimal point blinks rapidly when in the metric mode.

The P1000 may be used to display frequency instead of tension by entering a two key sequence. Entering the same sequence restores display of tension.

2.0 SPECIFICATIONS

1. Overall Tension Range*	0.0044 lbs (2 grams) to 9999 thousand pounds (4448 KN)
2. Overall Frequency range	1 Hz to 300 Hz
3. Accuracy	±1%
4. Resolution	0.01%
5. Material Diameters or width*	250 microns dia. to 6 ft width (0.000635 cm - 182.9 cm)
6. Span Length	0.5 to 328 feet (0.106 m to 99.99 m)
7. Pickup Transducers	Proximity probe (see page 9) Contact probe (see page
8. Power Source	Self-contained, Rechargeable battery (Charger supplied with the instrument)
9. Temperature Range	-20° to +65° centigrade at specified accuracy
10. Weight	5 lb. (22.24 N)
11. Size	Height: 4" (10.2 cm) Width: 10" (25.4 cm) Depth: 9 1/4"(23.5 cm)
12. Case	ABS Plastic case with strap, in cloth pouch

*Tension range may be extended by the procedure in paragraph 15.0.

3.0 PREPARING TO USE THE P1000

- 2.1 Determine the span between two bridge points - See 4.0
- 2.2 Determine the weight per foot of the material. - See 5.0
- 2.3 Determine Kfactor - See 6.0
- 2.4 Select sensor - See 7.0
- 2.5 Make keypad entries - See 8.0
- 2.6 Set ON/OFF switch
- 2.7 Position the sensor - See 9.0
- 2.8 Excite the material - See 10.0
- 2.9 Read the tension - See 13.0

4.0 DETERMINING THE SPAN

4.1 SPAN LENGTH MEASUREMENT Span length is the distance between two support points. The supports perform the same function as frets on a guitar, so they must be solid. Sheaves, bulkheads, tie downs or other restraints are good bridge points. Your imagination is the only limitation in the selection of bridge points since they can easily be improvised, if not already present. Accuracy of length measurement is very important. A 1% error in length input will cause a 2% error in the tension reading. Appendix F provides guidelines for creating bridge points where no natural ones exist.

As the cable length to diameter ratio decreases, the vibration decay time also decreases. It is necessary that decay time be long enough to allow a few cycles of vibration to be processed by the P1000. As length to diameter ratio increases, decay time also increases, but vibration frequency decreases. Therefore, the length to diameter ratio must be greater than some minimum, determined by the combination of decay time and vibration frequency. Because frequency varies with tension, the minimum L/D ratio varies with tension also. Charts in Appendix D show minimum ratios of span lengths to cable diameters versus tension.

4.2 DEALING WITH A PARTIALLY SUBMERGED SPAN

In applications where all or part of the span is submerged in fluid, such as seawater, the effective weight per foot is greater than that of the span in air. Acceleration of the fluid immediately surrounding the cable effectively increases its mass. Only the submerged portion adds to the effective mass. This effective added mass (EAM) may be corrected for by adding its value to the weight per foot in air and multiplying the sum by the ratio of submerged span to total span.

For a cylinder, the EAM equals the cylinder volume times the fluid density. The volume of one unit length is $\pi D^2/4$. The EAM is therefore $\pi D^2/4\rho L_i/L_s$, where D is the cylinder diameter, ρ is the density of the fluid, L_i is the submerged length, and L_s is the total span length. **EAM for a cable in seawater in English units is $0.349 D^2 L_i/L_s$. EAM for a cable in seawater in metric units is $0.08066 D^2 L_i/L_s$. For chain, consider the links as two parallel cylinders. To determine EAM for chain simply multiply the appropriate formula by two.**

It should be noted that for the majority of applications, the correction term is so small it may be ignored. For example, the EAM correction for a cable with 25% of a 40-foot span immersed is 4.7% of the weight per unit length. Since tension varies directly with weight per unit length, not correcting for EAM will result in a 4.7% error in tension measurement. The error for chain under the same conditions would be less, because the chain weight in air is several times more than cable weight in air, but EAM is only twice as great. EAM is therefore, a smaller percentage.

4.3 DEALING WITH TURNBUCKLES AND END FITTINGS

In many applications, the span includes end fittings at each end and a turnbuckle at one end. Usually, the end fittings are short relative to the total span length and are simply included in the span measurement. Turnbuckles, however may need to be bypassed or compensated. The bypass way is shown in Appendix F. It entails creating a bridge point inboard of the turnbuckle, so it is outside the span.

A second way is to correct for the added mass of the turnbuckle. To do that, the cable unit weight is increased by the weight of the turnbuckle. The length of the turnbuckle (L_t) is included in the span. Measure the cable length and the turnbuckle length. Multiply the cable weight per unit length by its length. Add to that the weight of the turnbuckle. Divide the sum of the weights by the sum of the lengths. Enter that number as the weight per unit length into the P1000.

Appendix C lists representative turnbuckle weights and lengths.

5.0 DETERMINING WEIGHT PER FOOT

Appendix A lists the weight per foot of Independent Wire Rope Center, Fiber Core wire rope weights and chain weight. **A convenient rule of thumb for estimating the weight of IWRC cable is multiply the diameter squared by 1.85 lb/ft (2.76 kg/m).**

For ropes not listed in the tables the weight per foot can be obtained from the manufacturer, or a sample can be weighed. The calculated tension is directly proportional the weight per unit length. For example, a 1% error in the weight entry causes a 1% error in the tension displayed.

If all or part of the span is immersed, follow the instructions in Paragraph 4.2. If the span includes a turnbuckle, follow the instructions in Paragraph 4.3.

6.0 COMPENSATING THE READINGS FOR MAXIMUM ACCURACY

Because materials under tension have some measure of stiffness, the vibration frequency equation contains a term that is related to stiffness, independent of tension. That term in the equation represents an error in tension measured by *DynaTension*[®]. The effect is inversely proportional to the square of the length of the span. Therefore, only on short spans is it of much consequence. In those cases, compensating for it is relatively simple.

In most cases tension readings obtained directly from the P1000 may be used without any compensation at all. For those cases where it is considered necessary for the best possible accuracy, a compensating value called Kfactor can be entered into the P1000. It will henceforth make the necessary correction, unless the wire rope diameter changes. In that case, a new value of Kfactor must be entered. Kfactors have been computed for several typical sizes and types of wire rope. Those compensating values are tabulated in Appendix B.

6.1 KFACTOR FROM THE TABLE IN APPENDIX B

If in the English mode and cable diameter is between ¼” and 1 7/8”, enter via the keypad, **120B**; if diameter is between 2 inches and five inches, enter **1200B**. If in the metric mode and diameter is between 6 mm and 32 mm, enter **300B**; if diameter is between 35 and 108 mm, enter **3000B**. To enter Kfactor, look up the wire rope diameter in the Kfactor table in Appendix B. For English mode use the table on page B1, for metric mode, use the table on page B2. Next, look across the row to the appropriate rope construction column. Enter the number in the column corresponding to the wire rope type and diameter you’re using. Enter **#A** to store that value of Kfactor. Finally, enter the actual span on which you’re measuring tension, followed by **B**. The P1000 will automatically calculate the correct Kfactor and subtract it from all subsequent readings. If you change to a different cable type or diameter, enter the new Kfactor by the same procedure.

To find compensation values for wire rope constructions not listed in the tables, use the construction nearest to one of those listed.

Example: 6 x 37 use 6 x 36 table
 6 x 21 use 6 x 25 table
 5 x 26 use 6 x 25 table, etc.

6.2 MEASURING THE KFACTOR

For such cables as electromechanical or optomechanical, or for chain, belt or webbing, no simple tables can be prepared without detailed knowledge of the construction. However, Kfactor for any particular item can be measured with the P1000. The method entails making two tension measurements, each at different points along the span and solving two simultaneous equations.

The step-by-step procedure is as follows:

- 1) Enter **0 #A** via the keypad.
- 2) Create a span by introducing bridge points at two locations in a specimen under tension.
- 3) Carefully measure the length of the span and record it as L1.
- 4) Measure the tension in the span and record the reading as T1.
- 5) Create a bridge point near the middle of the span (apply no more force than necessary to create a solid bridge point).
- 6) Carefully measure either half of the span and record the length as L2.
- 7) Enter L2 via the keypad, measure and record tension T2.
- 8) Subtract T1 from T2.
- 9) Square (L2/L1).
- 10) Divide (T2-T1) by $(1 - (L2/L1)^2)$. The result is the Kfactor for that material with the span length L2. Record it as Kf2.
- 11) Enter the value of Kf2 followed by **# A** via the keypad. The P1000 will compensate all subsequent readings of tension in material of that construction. It will remember the correct Kfactor and adjust it for different span lengths that may subsequently be entered into the P1000.
- 12) If the P1000 is used to measure tension in material of other construction, repeat steps 1 through 11 above.

6.2 CALCULATING THE KFACTOR

The Kfactor may be calculated from the algorithm $(\pi/L)^2 EI$. L is the span length, E is the modulus of elasticity and I is the area moment of inertia.

7.0 SELECTING THE MOST SUITABLE SENSOR

Any one of four sensors may be chosen for use with the P1000 tension computer. They are: the VARI-L (101), the (EOSENS (102), ACSENS (103), or the USENS (104). The best choice is determined by the application. The key attributes of each sensor and typical applications are discussed below.

7.1 LONG SPANS OF LARGE CABLE OR CHAIN (Also see section 10.0)

A typical application is measurement of anchor line tensions on offshore drilling platforms. For this type of application, the vibration frequency is low, usually from one to ten Hertz. The bandwidth of the 101 and the 104 is 1 Hz to 300 Hz. Either sensor can be used for this type of application. The 101 can only sense vibration of metal, whereas the 104 can sense any kind of material.

The 101 must be held or placed less than $\frac{3}{4}$ " (19 mm) from the material. Whereas the 104 can sense vibration from a distance as great as 30 (762 mm) inches and no less than five inches (127 mm). It would be used where operator safety is a major consideration.

7.2 MEDIUM SPANS – DIAMETERS UP TO TWO INCHES (51 MM)

Typical applications are elevator cables, or fabric roof support cables, or geophysical tow cables. The bandwidth of either the 101 or the 104 is again suitable. Either can be used with running cable. The 101 may be a little easier to hold in place, but will not work with the non-metallic tow cable.

The 103 sensors can also be used for the majority of such applications if the cable is not running. Its bandwidth is five Hz to 300 Hz. The primary advantage of the 103 is convenience. It "sticks" onto the cable and doesn't have to be held in place. Possible error due to hand motion is eliminated.

7.3 SHORT SPANS – DIAMETERS UP TO ¼ INCH (6 MM)

The 102 sensor is designed specifically for such applications, although its bandwidth is one Hz to three hundred 300 Hz. It is very sensitive and is best mounted in place rather than hand-held.

It is typically used to measure tension in filaments and small belts. It may be used with either metallic or non-metallic, either moving or non-moving materials.

8.0 KEYPAD ENTRIES

After turn-on or reset, wait a second or two before pressing a number, letter, or symbol key.

A Stores cable weight in pounds per foot or kg per meter

B Stores length in inches or centimeters

C Display reset - push once to reset display to zero

D Decimal point

#A Stores K FACTOR

#B Display HOLD - Remains in normal mode but holds the last reading. Press **#**, then **B** to make display hold or **#** then **B** to return to normal mode. Hold mode is indicated by a solid colon.

#C Calibration check - Press **#**, then **C** to check calibration

#D English/Metric units - Press **#**, then **D** to switch from English to metric and vice versa. Metric mode is indicated by a blinking decimal point. A solid decimal point indicates English mode.

#1 Error Window - Enter number in % allowable error, then press **#1**

System rejects errors greater than the number entered. Because the initial strum inputs a momentary increase in tension, it is best to set the window at 1.0 % to 2.0% so it is large enough to accommodate the strum transient.

#2 Readings averaged - Enter number, then press **#2**

Each value displayed is the average of N readings, where N is one plus the number entered. The system reads every other cycle up to a maximum of twelve readings per second.

#3 Scales display by 1000 - Enter **1**, then **#3**.

System displays in pounds or Newtons instead of KIPS or KN. To return to the normal scale, enter **0**, then **#3**.

#4 Compensates for contact probe weight - Enter 0.013(English) or 0.006 (metric), then **#4**. To return to proximity probe use, enter **0**, then **#4**.

#5 Reading hold time - Enter number of seconds, then **#5**

Time each reading is held (when not in hold or snapshot mode) may be varied with resolution of 0.01 seconds

#6 Snap Shot Mode - Takes a very quick sample of a rapidly decaying signal.

Enter **#6** to turn on. Enter **#6** again to return to normal mode. Vibration in short spans under high tension decays very quickly and only a very few cycles are available for processing. The result is, this mode is the least accurate. Approximately $\pm 5\%$ to $\pm 10\%$ error in tension readout may result. This mode is indicated by a blink off by the colon for 0.1 seconds at a rate corresponding to the **#5** setting.

#7 Frequency Readout Mode - Displays frequency, doesn't care about Weight or Length. Enter **#7** again to switch to Tension Readout Mode. **Frequency mode is indicated by display of P when no signal is present.**

<u>Vibration Bandwidth Entries:</u>	<u>Maximum Span</u>
0#8 18 Hz to 300 Hz	16 ft (4.9 m)
1#8 3.2 Hz to 300 Hz	92 ft (28 m)
2#8 0.4 Hz to 30 Hz (CAL CHECK DISABLED)	> 92 ft (28 m)
3#8 0.3 Hz to 30 Hz (CAL CHECK DISABLED)	

In general, select the **#8** values shown if spans are greater than the maximum spans listed above.

When measuring tension or frequency of vibration in short, lightweight material, such as small belts or filaments, a bandwidth setting of 18 Hz to 300 Hz is usually appropriate. The purpose in limiting the bandwidth is to block strum transients in rapidly decaying vibration signals, which may range up to 300 Hz, or so. In general, program the highest bandwidth that results in repeatable measurements. The bandwidth is set during manufacturing at 3.2 Hz to 300 Hz because it covers the vibration spectrum in a very wide variety of applications.

NOTE: When in # 6 mode, the first reading after causing the material to vibrate is not displayed. The vibration must be present only a few cycles after each succeeding vibration excitation, to result in display of a newly calculated value of tension. Each reading is held until the signal decays below threshold or the sensor is removed. Pressing "C" to clear the display will restart the above process. A 0.1 second blink of the colon at a rate determined by the #5 setting indicates the time at which a new reading can be made. The #5 setting

must be at least 1.0 to allow transients to decay. Unlimited samples can be taken and displayed on the same material without pressing "C". However, if any parameters change such as switching to a new cable, the "C" key must be depressed.

NOTE: The following inputs are retained when power is off: Weight or Mass; Length; Hold; English or Metric; K FACTOR; Error Window; Readings Averaged; ACSENS Weight compensation; Reading Hold time, P mode, Bandwidth. To change any one of these scale display parameters, enter the new value as appropriate according to the table above.

8.1 ERROR/MODE CODES

E 01 - Length out of range

E 02 - Frequency out of range

E 03 - Tension out of range

9.0 POSITIONING THE SENSOR

9.1 VARI-L PROBE

The VARI-L proximity transducer does not require attachment to the cable. However, it can only be used if the cable is metal or has armor that is metal material. The lower frequency bandwidth of the VARI-L is one Hertz, unless otherwise specified at the time of purchase. Because of its low frequency response, it can be used on long spans under low tension. Its sensitivity varies with size of the target, up to about one inch. Targets smaller than 1/8" in diameter may not provide adequate signal amplitude to measure the tension.

The VARI-L proximity probe should be positioned alongside and parallel to the cable, about one quarter to one half inch away from it. **The side of the sensor with a white circle or dot should face the cable.** If the probe is held by hand, it is important to hold it very still. Simply resting a finger of the hand holding the probe on some surface, such as an adjacent cable, usually provides adequate stability. On large cable or chain, lightly resting a finger of the hand holding the probe on the material will help to hold the probe steady.

9.2 EOSENS PROBE

The EOSENS probe also requires no physical contact with the material under tension. It is designed especially for measuring tension in very small, or very light weight material. However, it can also be used for any material, of any size. The low frequency cut-off of the EOSENS is the same as the VARI-L. It is best suited to measurement of tension in short spans of lightweight material. The EOSENS has very high sensitivity and is very difficult to hold by hand steady enough to obtain good readings. Two mounting holes are provided for fixed installation.

The sensor is positioned about one 1/8 inch to one and a half or two inches from the vibrating surface, depending on the size and reflectance of the target. An indicating LED is added to the EOSENS probe to aid in positioning the sensor. Beside the LED is a knob that is used to adjust the sensitivity of the LED.

9.2.1 MEASURING TENSION IN FILAMENT

To position the sensor for measuring tension in very small material such as optical fiber, first position the sensor-face either toward the ground or away from any light source or nearby object. Adjust the knob so the LED is fully lit. Now, adjust the knob slowly to the point at which the LED turns off. The spot size that paints the target will be about 0.25 inch in diameter. Move the probe closer or farther from, and from side to side of the target to maximize the intensity. Once the distance that yields maximum intensity is found, position the probe roughly midway between that point and the material surface. Usually, bandwidth setting should be 18-300 Hz for filament.

NOTE: If there is a reflecting surface within a few inches beyond the target, it may be necessary to mount a flat black material behind the target. This prevents energy reflected from the background surface from biasing the sensor at a non-optimum operating point. Also avoid orienting the sensor toward a light source. If the target is reflective, such as aluminum sheet or white paper, overhead lights reflected by the surface may cause erroneous readings or an E03 message. To prevent the problem, place a shield between the offending light source and the area directly over the sensor.

9.2.2 MEASURING TENSION IN BELTS

When using the EOSENS probe with larger material such as belt, point the sensor face toward the ground or away from any light source or nearby object. Adjust the knob so the LED is fully lit. Now adjust the knob slowly to the point at which the LED turns off. Then place the probe before the target at the position where the LED begins to light. Optimum position is where the LED flickers (not too bright and not too dim) when the target is deflected. Black automotive type belts require placement of the sensor very close to the belt, on the order of 1/16" to 1/8". Other, lighter color or smoother textured belts may require placing the sensor on the order of an inch or two from the surface. In all cases, resting on a firm support, if possible, should steady the hand holding the sensor. Usually, the bandwidth setting should be 18 - 300 Hz for small belts, with lengths of one or two feet. It should be 3 - 300 Hz for larger belts with longer spans.

9.3 ACSENS PROBE

The contact probe is designed especially for measuring tension in short spans under high tension. Its use eliminates possible error caused by hand motion. It has a low frequency response of 5Hz. The contact probe has a magnet in its base, which holds it on ferrous material. For non-ferrous material, it may be attached with tape, such as electrical tape or masking tape. If the material weight/foot, multiplied by the span in feet is less than 4 pounds, use the **#4** mode (**see paragraph 8.0 on page 10**).

The weight of the sensor influences the vibratory response of the cable, which in turn degrades the instrument accuracy, if the material is lightweight. It is best to use the 103 sensor only on material that is 0.5 lb/ft or greater. If it's desired or necessary to use it on smaller material, it should be calibrated for that material. To calibrate it, clear the **#4** mode by entering **0#4**. Apply a known load to the material and increase the Weight input as necessary to obtain a reading that is the same as the known load.

When using the contact probe it is advisable to pinch a small amount of soft, mildly adhesive material between the edges of the probe and the cable. This prevents the probe from "wobbling" which creates unwanted signals. A small square of butyl rubber is shipped with each unit for that purpose. Often, the butyl provides an adequate adhesive to hold the sensor on the material.

10.0 EXCITING THE MATERIAL

The material should be excited no more than necessary to get a stable reading. Over-exciting the material is a frequent cause of difficulty in getting stable readings. Vibration amplitude of 1/8" (3.2 mm) is more than adequate for any of the sensors.

A good guideline to follow is be gentle. Tables in Appendix E list the amount of force required to properly excite the material. Note that the required amount of force decreases as the span length increases, and that less force is required near mid-span. Also note that the forces shown are those required to displace the material.

Exciting the material by hitting it or tapping it accelerates the mass of cable. Accelerating the material requires an additional inertial force. Whenever possible, use a gentle pull or push instead of striking it. The subparagraphs below provide guidance for typical situations.

10.1 LONG SPANS OF LARGE CABLES OR CHAIN

To excite very long spans of large cable or chain, such as a vessel mooring line, push against it to deflect it slightly, and then quickly release the pressure. With the hand resting lightly on the material, reinforce the vibration, causing it to vibrate with ever-increasing amplitude. When the amplitude is at least 1/16" (1.6 mm), hold the sensor 1/4" (6.4 mm) to 1/2" (12.7 mm) from the material to read tension. On heavy cable or chain, a finger of the hand holding the sensor can rest lightly on the material to help hold it steady.

10.2 SHORT SPANS OF LARGE CABLES

Striking them with a sledgehammer may excite short spans of large cables. However, vibration decays very quickly. Therefore use the SNAP SHOT mode for this type of application (see pages 11,12).

NOTE: It is not possible to excite large chain with a sledgehammer. A method that has been employed is to pay out and in one link. The "jerk" on the chain excites it into vibration.

10.3 LONG SPANS OF SMALL CABLES

Long spans of small cables are best excited by plucking them gently or pushing on them to get vibration started, then re-enforce the vibration if necessary to get enough amplitude of vibration.

Plucking or pushing too hard can result in exciting the **second harmonic** (see page 2) instead of the **fundamental** (see page 2). If that happens, the tension displayed will be four times too high. If readings do appear to be four times too high, stop the cable from vibrating, then try exciting it again very gently. After re-exciting the cable, if readings still appear to be four times too high consistently, divide the reading by four and use that value as the true tension.

10.4 SHORT SPANS OF SMALL CABLES

Short spans of small cables or belts are best excited by tapping with a quick tap like a piano key striking a piano wire, or a doctor testing for a nerve/muscle reflex. In fact, a “knee knocker” is an excellent tool for this type of application. Try to minimize “dwell” of the exciter on the material by snapping it back quickly. If the exciter dwells on the material, it can damp and kill the vibration. Excitation should be done as near to mid-span as possible, to minimize creation of unwanted higher harmonics.

10.5 VERY LIGHT WEIGHT MATERIALS

Very light weight materials such as optical fiber, or other filament is best excited by brushing it gently with a small brush, like a violin bow is drawn across the violin strings. An alternate way is to excite it with a pulse of air. For in-situ operation, applying bursts of compressed air using an electrically operated air valve with a nozzle works quite well. The airbursts should be no longer than 10 milliseconds in duration.

11.0 BATTERY SUPPLY

IF THE BATTERY IS TOO LOW FOR RELIABLE OPERATION, THE COLON IN THE MIDDLE OF THE DISPLAY WILL BLINK ON AND OFF. Either of two chargers is normally provided with each P1000. European chargers operate with 240V/50Hz power input. Domestic chargers use 120V/60Hz power input. To charge the battery, plug the charger into an appropriate outlet and insert the charger plug into the power jack on the rear panel of the P1000. Allow the unit to charge for ten hours. A longer charge time will not damage the battery. The P1000 should operate satisfactorily for at least fifteen hours between charges. **The P1000 should not be used to measure tension with the charger plugged in.**

12.0 VERIFYING INSTRUMENT ACCURACY

Even though your *DynaTension*[®] instrument is a very stable device, you may wish to occasionally check the calibration. It is recommended that you do so if the unit has been shipped, or if it has been dropped or otherwise damaged.

The procedure for calibration check is as follows:

1. Ensure the instrument is in the English mode (if the decimal point is blinking, press # followed by **D**).
2. Press **1#8** to set bandwidth greater than 50Hz.
3. Key in weight of 25.74 lb./ft - **A**.
4. Key in length of 100 inches - **B**.
5. Push the # key followed by the **C** key once.
6. The display should read 555.5 ± 5.555 KIPS in tension mode or 49.99 to 50.00 Hz in frequency mode.
7. Press # followed by **D**.
8. The display should read 257.4 ±2.574 KN or 49.00 to 50.00.
9. Press # then **C** to return to operate mode.
10. If vibration frequency is 30 Hz or less decrease bandwidth by entering **2#8** or **3#8** (see page 6 for Vibration Bandwidth entries).

If you do not observe the correct readings, contact your *DynaTension*[®] distributor.

NOTE: If in frequency display mode, CAL CHECK reading should be 49.75 to 50.25. To switch to the tension display mode, enter #7 via the keypad.

13.0 MAKING A TENSION MEASUREMENT

- A. Plug the transducer into the jack marked INPUT.
- B. Position the proximity transducer (VARI-L) adjacent to the cable in the plane of vibration, e.g., if vibration is up and down, place it above or below the cable with the epoxy side facing away from the cable. The probe should be placed about one quarter to one half inch (one half to one centimeter) from the cable. Avoid trying to measure tension close to one of the bridge points, if possible. If the contact probe is used, attach it to the cable in the same orientation. Also, it is important on small cables, to hold the contact probe cable, or affix it to the cable so it doesn't pull on the transducer.
- C. Cause the cable to vibrate by tapping it or plucking it.

- D. The tension reading may fluctuate a little at first while the instrument is computing tension. Wait for the readout to stabilize, and then read the tension.
- E. If, after several attempts to do so, you fail to get a stable reading on a short length of cable, you may have to select a longer span length. If you fail to get good, stable readings on longer spans examine the rigidity of the bridge points.
- F. When tension measurements have been completed, always remember to turn the instrument OFF to conserve the battery charge. A badly run down battery takes longer to charge than one that requires only routine charging.

14.0 MEASURING FREQUENCY

Entry of span length or material weight is not required. Simply enter **#7** via the keypad and excite the material. Regardless of which sensor is in use, the P1000 will display the fundamental frequency of vibration of the material. The vibration frequency of any surface, for example, can be measured by placing the ACSSENS sensor on the surface and reading the value displayed. Non-intrusive measurements of vibration frequency may be made with any of the three proximity probes. The P1000 may be made to alternately display frequency or tension by toggling the **#7** entries.

15.0 EXTENDING THE INSTRUMENT RANGE

If the cable weight per foot is less than 0.1000 lb./ft or 0.1000 kg/m, shift the decimal point to the right and divide the tension reading by the same power of ten. As an example, if the weight is 0.0111 lb./ft, enter the weight as 0.111 and divide the tension displayed by 10. As another example, if the weight is 0.000111 kg/m, enter the weight as 0.111 and divide the tension displayed by 1000.

To convert full scale tension from kilo-pounds or kilo-Newtons to pounds or Newton's, simply multiply the weight/ft by 1000 and enter that value. For example, 1/8" wire rope may have a weight of 0.029 lb./ft. To readout directly in pounds, enter W as 29 instead of 0.029. Full scale will then be 999.9 pounds and minimum resolution will be 0.001 pound.

NOTE: A KFACTOR ENTRY PREVIOUSLY STORED WILL NOT BE PROPERLY SUBTRACTED. IF KFACTOR IS A CONSIDERATION, AND A 1000:1 INCREASE IN SENSITIVITY IS DESIRED, ENTER 1 #3, THEN ENTER THE KFACTOR.

16.0 TROUBLE-SHOOTING THE INSTRUMENT

1. Recheck all keypad entries.
2. Erratic readings may be caused by movement of the sensor while making a measurement, or by inadequately firm bridge points.
3. Be sure that the support points at each end of the span are firmly in contact with the wire rope and that no other object is touching the wire between bridge points.
4. Should service become necessary, contact your distributor for shipping instructions.

APPENDIX A

CABLE WEIGHT/FOOT TABLES

INDEPENDENT WIRE ROPE CENTER WIRE ROPES

DIAMETER INCHES	LB/FT	DIAMETER MILLIMETERS	KG/M
1/4	0.116	6	0.154
5/16	0.18	8	0.273
3/8	0.26	10	0.427
7/16	0.35	11	0.517
1/2	0.46	13	0.722
9/16	0.59	14	0.837
5/8	0.72	16	1.093
3/4	1.04	19	1.541
7/8	1.42	22	2.067
1	1.85	25	2.669
1 1/8	2.34	29	3.591
1 1/4	2.89	32	4.372
1 3/8	3.50	35	5.230
1 1/2	4.16	38	6.165
1 5/8	4.88	41	7.177
1 3/4	5.67	44	8.266
1 7/8	6.50	48	9.837
2	7.39	51	11.11
2 1/8	8.39	54	12.45
2 1/4	9.36	57	13.87
2 3/8	10.40	60	15.37
2 1/2	11.60	64	17.49
2 5/8	12.80	67	19.17
2 3/4	14.00	70	20.92
3	16.60	76	24.66
3 1/8	18.00	79	26.65
3 1/4	19.50	83	29.41
3 3/8	21.00	86	31.58
3 1/2	22.70	89	33.82
3 3/4	26.00	95	38.53
4	29.60	102	44.42

FIBER CORE WIRE ROPES

DIAMETER INCHES	LB/FT
1/4	0.105
5/16	0.164
3/8	0.236
7/16	0.32
1/2	0.42
9/16	0.53
5/8	0.66
3/4	0.95
13/16	1.11
7/8	1.29
1	1.68
1 1/16	1.9
1 1/8	2.13
1 3/16	2.37
1 1/4	2.63
1 3/8	3.18
1 7/16	3.47
1 1/2	3.78
1 5/8	4.44
1 11/16	4.78
1 3/4	5.15
1 13/16	5.52
1 7/8	5.91
1 15/16	6.31
2	6.77
2 1/16	7.15
2 1/8	7.58
2 1/4	8.51
2 5/16	8.98
2 3/8	9.48
2 1/2	10.5
2 5/8	11.6
2 3/4	12.7
2 7/8	13.9
3	15.1
3 1/8	16.4
3 1/4	17.7
3 3/8	19.1
3 1/2	20.6
3 3/4	23.6
4	26.9

DIAMETER MILLIMETERS	KG/M
6	0.140
8	0.248
10	0.388
11	0.469
13	0.655
14	0.760
16	0.993
19	1.400
22	1.877
25	2.423
29	3.261
32	3.970
35	4.750
38	5.599
41	6.518
44	7.507
48	8.933
51	10.09
54	11.31
57	12.60
60	13.96
64	15.88
67	17.41
70	19.00
76	22.40
79	24.20
83	26.71
86	28.68
89	30.71
95	34.99
102	40.34
67	17.24
70	18.92
73	20.68
76	22.51
79	24.43
83	26.42
86	28.49
89	30.64
95	35.18
102	40.02

STUD LINK CHAIN ENGLISH UNITS		STUD LINK CHAIN METRIC UNITS		DI-LOK CHAIN ENGLISH UNITS		DI-LOK CHAIN METRIC UNITS	
SIZE (IN)	POUNDS/ FOOT	SIZE (MM)	KG/ METER	SIZE (IN)	POUNDS/ FOOT	SIZE (MM)	KG/ METER
5/8	3.69	15.9	5.49	3/4	5.14	19.1	7.66
3/4	4.89	19.1	7.28	13/16	6.12	20.6	9.11
13/16	5.82	20.6	8.66	7/8	7.15	22.2	10.7
7/8	6.74	22.2	10.0	15/16	8.11	23.8	12.1
15/16	7.76	23.8	11.6	1	9.19	25.4	13.7
1	8.78	25.4	13.1	1 1/16	10.4	27.0	15.5
1 1/16	9.92	27.0	14.8	1 1/8	11.7	28.6	17.4
1 1/8	11.2	28.6	16.7	1 3/16	13.0	30.2	19.4
1 3/16	12.5	30.2	18.5	1 1/4	14.5	31.8	21.6
1 1/4	13.8	31.8	20.6	1 5/16	16.0	33.3	23.8
1 5/16	15.3	33.3	22.7	1 3/8	17.3	34.9	25.8
1 3/8	16.6	34.9	24.7	1 7/16	18.9	36.5	28.2
1 7/16	18.1	36.5	26.9	1 1/2	20.7	38.1	30.8
1 1/2	19.7	38.1	29.3	1 9/16	22.4	39.7	33.4
1 9/16	21.3	39.7	31.8	1 5/8	23.9	41.3	35.5
1 5/8	22.2	41.3	33.0	1 11/16	25.7	42.9	38.3
1 11/16	24.5	42.9	36.5	1 3/4	27.7	44.5	41.3
1 3/4	24.8	44.5	36.9	1 13/16	28.9	46.0	43.1
1 13/16	28.6	46.0	42.5	1 7/8	31.8	47.6	47.3
1 7/8	30.3	47.6	45.1	1 15/16	33.8	49.2	50.3
1 15/16	32.2	49.2	48.0	2	36.1	50.8	53.8
2	34.4	50.8	51.3	2 1/16	38.4	52.4	57.2
2 1/16	36.6	52.4	54.5	2 1/8	40.8	54.0	60.8
2 1/8	38.9	54.0	57.9	2 3/16	42.7	55.6	63.6
2 3/16	40.7	55.6	60.7	2 1/4	45.4	57.2	67.6
2 1/4	43.3	57.2	64.5	2 5/16	47.5	58.7	70.7
2 5/16	45.3	58.7	67.4	2 3/8	50.4	60.3	75.1
2 3/8	48.1	60.3	71.6	2 7/16	52.5	61.9	78.2
2 7/16	50.0	61.9	74.4	2 1/2	56.4	63.5	83.9
2 1/2	53.7	63.5	80.0	2 9/16	58.9	65.1	87.7
2.75	65.5	69.9	97.6	2 5/8	61.6	66.7	91.7
2 13/16	68.5	71.4	102	2 11/16	65.7	68.3	97.8
2 7/8	71.6	73.0	107	2 3/4	68.8	69.9	102
2 15/16	74.8	74.6	111	2 13/16	71.9	71.4	107
3	78.1	76.2	116	2 7/8	75.1	73.0	112
3 1/16	80.8	77.8	120	2 15/16	78.5	74.6	117
3 1/8	85.4	79.4	127	3	82.1	76.2	122
3 3/16	87.2	81.0	130	3 1/16	85.8	77.8	128
3 1/4	91.1	82.6	136	3 1/8	89.7	79.4	134
3 5/16	95.1	84.1	142	3 3/16	91.5	81.0	136
3 3/8	100	85.7	148	3 1/4	95.6	82.6	142
3 7/16	104	87.3	155	3 5/16	99.9	84.1	149
3 1/2	106	88.9	158	3 3/8	104	85.7	156
3 5/8	116	92.1	173	3 7/16	109	87.3	163
3 3/4	123	95.3	183	3 1/2	111	88.9	166
3 7/8	132	98.4	196	3 5/8	120	92.1	178
4	139	102	208	3 3/4	129	95.3	193

**SUPER STRENGTH
DI-LOK CHAIN
ENGLISH UNITS**

SIZE (IN)	POUNDS\ FOOT
3/4	5.43
7/8	7.44
1	9.72
1 1/8	11.6
1 1/4	13.8
1 3/8	15.9
1 1/2	18.1
1 5/8	20.5
1 3/4	23.0
1 7/8	25.7
2	28.4
2 1/8	31.5
2 1/4	34.6
2 3/8	37.9
2 1/2	41.6
2 5/8	45.8
2 3/4	49.3
2 7/8	53.1
3	58.1
3 1/8	62.4
3 1/4	67.2
3 3/8	70.9
3 1/2	75.9
3 5/8	78.9
3 3/4	86.0
3 7/8	88.0

**SUPER STRENGTH
DI-LOK CHAIN
METRIC UNITS**

SIZE (MM)	KG/ METER
3/4	8.09
7/8	11.07
1	14.48
1 1/8	17.34
1 1/4	20.53
1 3/8	23.60
1 1/2	26.94
1 5/8	30.47
1 3/4	34.24
1 7/8	38.22
2	42.23
2 1/8	46.90
2 1/4	51.46
2 3/8	56.42
2 1/2	61.99
2 5/8	68.12
2 3/4	73.40
2 7/8	79.11
3	86.55
3 1/8	92.91
3 1/4	100.02
3 3/8	105.54
3 1/2	113.03
3 5/8	117.48
3 3/4	128.12
3 7/8	131.02

**U.S. NAVY
DI-LOK CHAIN
ENGLISH UNITS**

SIZE (IN)	POUNDS\ FOOT
3/4	5.04
7/8	7.06
1	9.23
1 1/8	11.7
1 1/4	14.6
1 3/8	17.6
1 1/2	21.0
1 5/8	24.0
1 3/4	24.8
1 7/8	32.2
2	35.8
2 1/8	41.0
2 1/4	45.7
2 3/8	50.7
2 1/2	56.7
2 5/8	63.2
2 3/4	69.1
2 7/8	75.6
3	82.5
3 1/8	88.6
3 1/4	96.6
3 3/8	105
3 1/2	112
3 3/4	130
4 3/4	211

**TYPE 2
HEAVY DUTY**

2 3/4	72.7
3	84.0
3 1/2	123

**TYPE 3 HIGH
STRENGTH**

3/4	5.66
1	10.4
1 1/8	13.2
1 3/8	19.8
1 1/2	23.6
1 5/8	27.1

APPENDIX B

KFACTOR COMPENSATION TABLES

KFACTOR WITH 10 FOOT SPAN - POUNDS					
DIAMETER	6X19 FC	6X19 IWRC	6X25 FC	6X25 IWRC	6X36 IWRC
1/4	3	5	3	3	5
5/16	8	11	8	8	11
3/8	16	23	16	17	23
1/2	28	41	28	28	31
9/16	41	66	41	45	60
5/8	66	96	66	66	96
3/4	141	206	128	128	187
7/8	275	365	250	250	365
1	442	630	442	486	630
1 1/8	740	1110	680	680	1040
1 1/4	1110	1630	1040	1040	1110
1 3/8	1630	2380	1500	1500	1630
1 1/2	2380	3170	2170	2170	2380
1 5/8	3170	4640	3170	3170	3170
1 3/4	4220	6019	3835	3835	4220
1 7/8	5610	8173	5100	5100	5610
KFACTOR WITH 100 FOOT SPAN - POUNDS					
2	73	105	73	66	99
2 1/8	93	134	93	84	126
2 1/4	116	168	116	106	159
2 3/8	145	209	145	131	197
2 1/2	178	256	178	161	242
2 5/8	216	311	216	196	294
2 3/4	260	375	260	236	354
3	368	531	368	335	501
3 1/8	433	625	433	394	590
3 1/4	507	731	507	461	690
3 3/8	590	850	590	536	803
3 1/2	682	983	682	620	928
3 5/8	785	1132	785	713	1068
3 3/4	899	1296	899	817	1223
3 7/8	1025	1478	1025	931	1395
4	1164	1678	1164	1058	1584
4 1/8	1316	1898	1316	1196	1791
4 1/4	1483	2138	1483	1348	2018
4 3/8	1665	2401	1665	1513	2266
4 1/2	1864	2687	1864	1694	2537
4 5/8	2080	2999	2080	1890	2831
4 3/4	2314	3336	2314	2103	3149
4 7/8	2567	3702	2567	2333	3494
5	2841	4096	2841	2582	3866

KFACTOR WITH 3 METER SPAN (NEWTONS)					
DIAMETER	6X19 FC	6X19 IWRC	6X25 FC	6X25 IWRC	6X36 IWRC
6	6	9	6	7	9
8	20	28	20	22	28
10	49	70	49	54	70
13	139	199	139	153	199
14	187	267	187	206	267
16	320	456	320	352	456
19	636	906	636	699	906
22	1143	1629	1143	1257	1629
25	1906	2716	1906	2095	2716
29	3450	4918	3450	3794	4918
32	5115	7291	5115	5624	7291
KFACTOR WITH 30 METER SPAN (NEWTONS)					
35	73	104	73	80	104
38	102	145	102	112	145
41	138	196	138	152	196
44	183	261	183	201	261
48	259	369	259	285	369
51	330	470	330	363	470
54	415	591	415	456	591
57	515	734	515	566	734
60	632	901	632	695	901
64	818	1167	818	900	1167
67	983	1401	983	1081	1401
70	1171	1669	1171	1288	1669
76	1627	2320	1627	1789	2320
79	1900	2708	1900	2089	2708
83	2315	3300	2315	2546	3300
86	2668	3803	2668	2934	3803
89	3061	4363	3061	3365	4363
92	3495	4981	3495	3843	4981
95	3973	5663	3973	4369	5663
98	4500	6413	4500	4947	6413
102	5280	7526	5280	5806	7526
105	5930	8452	5930	6520	8452
108	6637	9460	6637	7297	9460

APPENDIX C

TURNBUCKLE DATA

TURNBUCKLE DATA

	BODY	ROD END	OVERALL	WEIGHT/FT
3/8				
LENGTH	7 1/8	3.5	10 5/8	
WEIGHT	0.42	0.25	0.92	1.04
3/8				
LENGTH	7 1/8	5	12 1/8	
WEIGHT	0.42	0.25	0.92	0.911
1/2				
LENGTH	4 7/8	3.5	8 3/8	
WEIGHT	0.56	0.33	1.22	1.75
1/2				
LENGTH	7 9/16	6	13 4/7	
WEIGHT	0.65	0.5	1.65	1.46
1/2				
LENGTH	13 9/16	12	25 4/7	
WEIGHT	1.2	0.66	2.52	1.18
5/8				
LENGTH	4 7/8	3.5	8 3/8	
WEIGHT	0.56	0.55	1.66	2.38
5/8				
LENGTH	7 7/8	6	13 7/8	
WEIGHT	0.98	0.75	2.48	2.14
5/8				
LENGTH	12	12	24	
WEIGHT	2.35	1.25	4.85	2.43
3/4				
LENGTH	8 1/8	3.5	11 5/8	
WEIGHT	1.45	0.75	2.95	3.05
3/4				
LENGTH	11 1/8	6	17 1/8	
WEIGHT	1.84	1.25	4.34	3.04
3/4				
LENGTH	14 1/8	12	26 1/8	
WEIGHT	2.35	1.85	6.05	2.78

TURNBUCKLE DATA

	BODY	ROD END	OVERALL	WEIGHT/FT
7/8				
LENGTH	8 5/8	6	14 5/8	
WEIGHT	1.85	1.50	4.85	3.98
7/8				
LENGTH	14 7/8	12	26 7/8	
WEIGHT	4.00	2.60	9.2	4.11
1				
LENGTH	8 7/8	6	14 7/8	
WEIGHT	2.6	2.25	7.1	5.73
1				
LENGTH	14 7/8	12	26 7/8	
WEIGHT	4	3.47	10.96	4.89
1 1/4				
LENGTH	9 1/8	12	21 1/8	
WEIGHT	4	4.9	13.8	7.84
1 1/2				
LENGTH	15 1/8	12	21 3/4	
WEIGHT	9.74	8.75	27.24	15.0

APPENDIX D

ALLOWABLE LENGTH TO DIAMETER RATIO

ALLOWABLE LENGTH TO DIAMETER RATIOS

TENSION (LBS)	WIRE DIAMETER															
	0.125 INCH				0.25 INCH				0.5 INCH				1.0 INCH			
	PROXIMITY		CONTACT		PROXIMITY		CONTACT		PROXIMITY		CONTACT		PROXIMITY		CONTACT	
	MAX	MIN	MAX	MIN	MAX	MIN	MAX	MIN	MAX	MIN	MAX	MIN	MAX	MIN	MAX	MIN
10	422	170	84	30	106	170			26	300						
20	597	140	119	20	149	130			37	230						
50	944	100	189	20	236	100	47	30	59	170						
100	1335	80	267	10	334	80	67	30	83	130						
200	1887	70	377	10	472	60	94	20	118	110			29	210		
500	2984	50	597	10	746	50	149	20	187	80			47	160		
1000	4220	40	844	10	1055	40	211	20	264	70	53	30	66	120		
2000						30	298	20	373	50	75	30	93	100		
5000						30	472	10	590	40	118	20	147	70		
10000									834	30	167	20	209	60	42	40
20000									1180	30	236	20	295	50	59	30
50000													466	40	93	20

ALLOWABLE LENGTH TO DIAMETER RATIOS

TENSION (KIPS)	WIRE DIAMETER															
	2 INCH				3 INCH				4 INCH				5.0 INCH			
	PROXIMITY		CONTACT		PROXIMITY		CONTACT		PROXIMITY		CONTACT		PROXIMITY		CONTACT	
	MAX	MIN	MAX	MIN	MAX	MIN	MAX	MIN	MAX	MIN	MAX	MIN	MAX	MIN	MAX	MIN
100	1978	70	396	40	879	170	176	70	495	170	99		317	230	63	
200	2798	60	560	40	1243	130	249	60	699	130	140	80	448	180	90	
300	3427	50	685	30	1523	100	305	50	857	120	171	70	548	160	110	
400	3957		791		1759	80	352	50	989	110	198	70	633	140	127	90
500	4424		885		1966	60	393	40	1106	100	221	60	708	130	142	80
600	4846		969		2154	50	431	40	1211	80	242	60	775	130	155	80
700	5234		1047		2326	40	465		1309	70	262	60	837	120	167	70
800	5596		1119		2487	30	497		1399	50	280	50	895	120	179	70
900	5935		1187		2638	30	528		1484	40	297	50	950	70	190	70
1000	6256		1251		2780		556		1564	30	313	50	1001	60	200	60
1100	6561		1312		2916		583		1640	30	328	50	1050	50	210	60
1200	6853		1371		3046		609		1713		343	50	1097	40	219	60
1300	7133		1427		3170		634		1783		357		1141		228	60
1400	7402		1480		3290		658		1851		370		1184		237	60
1500	7662		1532		3405		681		1916		383		1226		245	60
1600	7913		1583		3517		703		1978		396		1266		253	60
1700	8157		1631		3625		725		2039		408		1305		261	60
1800	8393		1679		3730		746		2098		420		1343		269	60
1900	8623		1725		3833		767		2156		431		1380		276	60
2000	8847		1769		3932		786		2212		442		1416		283	50

ALLOWABLE LENGTH TO DIAMETER RATIOS

TENSION (N)	WIRE DIAMETER															
	3 MM				6 MM				13 MM				25 MM			
	PROXIMITY		CONTACT		PROXIMITY		CONTACT		PROXIMITY		CONTACT		PROXIMITY		CONTACT	
	MAX	MIN	MAX	MIN	MAX	MIN	MAX	MIN	MAX	MIN	MAX	MIN	MAX	MIN	MAX	MIN
44	422	170	84	30	106	170			26	300						
89	597	140	119	20	149	130			37	230						
445	944	100	189	20	236	100	47	30	59	170						
890	1335	80	267	10	334	80	67	30	83	130						
2224	1887	70	377	10	472	60	94	20	118	110			29	210		
4448	2984	50	597	10	746	50	149	20	187	80			47	160		
4448	4220	40	844	10	1055	40	211	20	264	70	53	30	66	120		
8896						30	298	20	373	50	75	30	93	100		
44480						30	472	10	590	40	118	20	147	70		
44480									834	30	167	20	209	60	42	40
88960									1180	30	236	20	295	50	59	30
222400													466	40	93	20

ALLOWABLE LENGTH TO DIAMETER RATIOS

TENSION (KN)	WIRE DIAMETER															
	5 CM				8 CM				10 CM				13 CM			
	PROXIMITY		CONTACT		PROXIMITY		CONTACT		PROXIMITY		CONTACT		PROXIMITY		CONTACT	
	MAX	MIN	MAX	MIN	MAX	MIN	MAX	MIN	MAX	MIN	MAX	MIN	MAX	MIN	MAX	MIN
445	647	70	129	40	287	170	57	70	162	170	32		103	230	21	
890	915	60	183	40	406	130	81	60	229	130	46	80	146	180	29	
1334	1120	50	224	30	498	100	100	50	280	120	56	70	179	160	36	
1779	1293		259		575	80	115	50	323	110	65	70	207	140	41	90
2224	1446		289		643	60	129	40	362	100	72	60	231	130	46	80
2669	1584		317		704	50	141	40	396	80	79	60	253	130	51	80
3114	1711		342		760	40	152		428	70	86	60	274	120	55	70
3558	1829		366		813	30	163		457	50	91	50	293	120	59	70
4003	1940		388		862	30	172		485	40	97	50	310	70	62	70
4448	2045		409		909	0	182	0	511	30	102	50	327	60	65	60
4893	2145		429		953	0	191	0	536	30	107	50	343	50	69	60
5338	2240		448		996	0	199	0	560		112	50	358	40	72	60
5782	2332		466		1036	0	207	0	583	0	117		373		75	60
6227	2420		484		1075	0	215	0	605	0	121		387		77	60
6672	2505		501		1113	0	223	0	626	0	125		401		80	60
7117	2587		517		1150	0	230	0	647	0	129		414		83	60
7562	2666		533		1185	0	237	0	667	0	133		427		85	60
8006	2744		549		1219	0	244	0	686	0	137		439		88	60
8451	2819		564		1253	0	251	0	705	0	141		451		90	60
8896	2892		578		1285	0	257	0	723	0	145		463		93	50

APPENDIX E

EXCITATION FORCE VS LENGTH AND TENSION

1000 LBS TENSION	EXCITATION FORCE (LB) REQUIRED AT POINT OF APPLICATION FROM BRIDGEPOINT								
	SPAN (FEET)	0.1	0.2	0.3	0.4	0.5	0.6	0.7	0.8
1	29	16	12	11	10	11	12	16	29
2	14	8	6	5	5	5	6	8	14
3	10	5	4	4	3	4	4	5	10
4	7	4	3	3	3	3	3	4	7
5	6	3	2	2	2	2	2	3	6
6	5	3	2	2	2	2	2	3	5
7	4	2	2	2	1	2	2	2	4
8	4	2	2	1	1	1	2	2	4
9	3	2	1	1	1	1	1	2	3
10	3	2	1	1	1	1	1	2	3
11	3	1	1	1	1	1	1	1	3

EXAMPLE: SPAN IS 5 FEET; TENSION IS 2000 LBS.
POINT OF FORCE APPLICATION IS AT 0.2 X 5 FEET, OR 1.0 FOOT;
EXCITATION FORCE REQUIRED IS 3 X 2000/1000, OR 6 POUNDS.

100 KIPS TENSION	EXCITATION FORCE (LB) REQUIRED AT POINT OF APPLICATION FROM BRIDGEPOINT								
	SPAN (FEET)	0.1	0.2	0.3	0.4	0.5	0.6	0.7	0.8
5	579	326	248	217	208	217	248	326	579
10	289	163	124	109	104	109	124	163	289
20	145	81	62	54	52	54	62	81	145
30	96	54	41	36	35	36	41	54	96
40	72	41	31	27	26	27	31	41	72
50	58	33	25	22	21	22	25	33	58
60	48	27	21	18	17	18	21	27	48
70	41	23	18	16	15	16	18	23	41
80	36	20	16	14	13	16	16	20	36
90	32	18	14	12	12	12	14	18	32
100	29	16	12	11	10	11	12	16	29

EXAMPLE: SPAN IS 50 FEET; TENSION IS 400,000 LBS.
POINT OF FORCE APPLICATION IS AT 0.5 X 50 FEET, OR 25 FEET;
EXCITATION FORCE REQUIRED IS 21 X 400000/100000 OR 82 POUNDS.

4448 N. TENSION	EXCITATION FORCE (N) REQUIRED AT POINT OF APPLICATION FROM BRIDGEPOINT								
	SPAN (CM)	0.1	0.2	0.3	0.4	0.5	0.6	0.7	0.8
30	129	71	53	49	44	49	53	71	129
61	62	36	27	22	22	22	27	36	62
91	44	22	18	18	13	18	18	22	44
122	31	18	13	13	13	13	13	18	31
152	27	13	9	9	9	9	9	13	27
183	22	13	9	9	9	9	9	13	22
213	18	9	9	9	4	9	9	9	18
244	18	9	9	4	4	4	9	9	18
274	13	9	4	4	4	4	4	9	13
305	13	9	4	4	4	4	4	9	13
335	13	4	4	4	4	4	4	4	13

EXAMPLE: SPAN IS 152 CM; TENSION IS 2000 N.
POINT OF FORCE APPLICATION IS AT 0.2 X 213 CM, OR 43 CM;
EXCITATION FORCE REQUIRED IS 9 X 2000/4448, OR 4 NEWTONS

445 KN TENSION	EXCITATION FORCE (N) REQUIRED AT POINT OF APPLICATION FROM BRIDGEPOINT								
	SPAN (METERS)	0.1	0.2	0.3	0.4	0.5	0.6	0.7	0.8
1.5	2575	1450	1103	965	925	965	1103	1450	2575
3	1285	725	552	485	463	485	552	725	1285
6	645	360	276	240	231	240	276	360	645
9	427	240	182	160	156	160	182	240	427
12	320	182	138	120	116	120	138	182	320
15	258	147	111	98	93	98	111	147	258
18	214	120	93	80	76	80	93	120	214
21	182	102	80	71	67	71	80	102	182
24	160	89	71	62	58	71	71	89	160
27	142	80	62	53	53	53	62	80	142
30	129	71	53	49	44	49	53	71	129

EXAMPLE: SPAN IS 21 METERS; TENSION IS 1112 KN.
POINT OF FORCE APPLICATION IS AT 0.2 X 21 METERS, OR 4.2 METERS;
EXCITATION FORCE REQUIRED IS 102 X 1112/445, OR 255 N.

NOTE: BY INITIATING CABLE DEFLECTION A VERY SMALL AMOUNT, THEN BUILDING IT UP BY
REINFORCING VIBRATION, THE CABLE INERTIA BUILDS AND PROVIDES THE NEEDED FORCE

APPENDIX F

ESTABLISHING BRIDGEPOINTS

I. BRIDGEPOINT AND SPAN

DynaTension's length boundaries range from a few inches for small belts and filaments to 341 feet for wire rope. The length we are referring to is called a "span". This is the distance between any two fixed points along the wire rope and has nothing to do with the overall rope length. The fixed points are called "bridgepoints" and consist of places where the rope is either firmly in contact with, or is attached to a stationary object. The stationary object can be a sheave, a bushing, a shackle, bulkhead, block of wood or any other material.

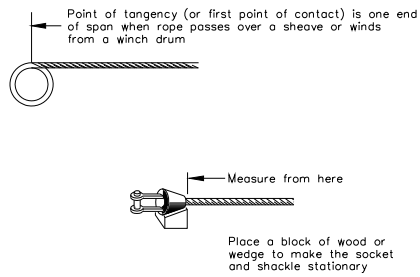

Fig. 1.

II. BRIDGEING GUY WIRES

Sometimes there are no conveniently located natural bridgepoints such as sheaves that produce appropriate span lengths. In these cases it is necessary to produce an artificial span length.

In guy wire tension measurement, for example; the length of the guy is usually excessive for DynaTension measurements without artificial bridgepoints. Artificial bridgepoints are introduced in several ways:

1. For small, lightly loaded guy wires:

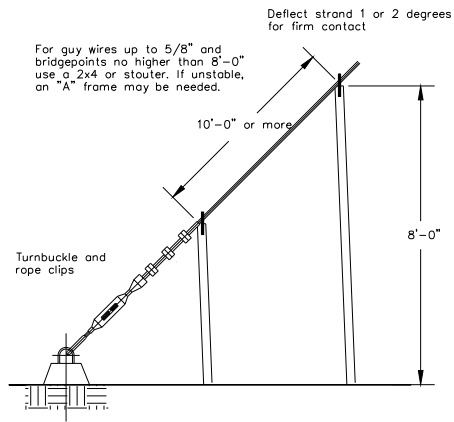

Fig. 2

2. For large diameter guy wires (over 5/8") or for heavily loaded ropes, the upper bridge can be produced by a telescoping hydraulic boom crane. This method provides the needed rigidity and reach for heavy loads often encountered in such cases. Remember to make the DynaTension measurements always near the center of the span, so a ladder or scaffold could be used to reach the rope under test.

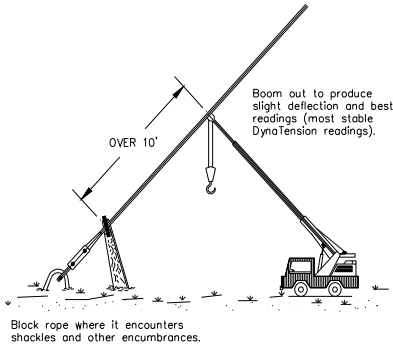

Fig. 3

NOTE:

The small deflections needed to produce an adequate bridgepoint will not significantly affect the tension on a long span, so bridge firmly enough to get a stable reading. Of course, even on a long span excessive deflection will cause problems. The rule is to use what you need but no more.

III. DYNATENSION BRIDGING OF CRANE LOAD LINES

The most satisfactory method of measuring crane loads is to produce an artificial bridge between the winch drum and a prop. This gives a convenient length of 10' to 20' to use with DynaTension.

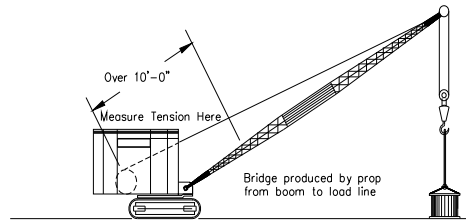

Fig. 4

Some cranes have boom stops conveniently located for making a bridge. On such cranes, bridge by wedging a board between the load lines and the boom stops.

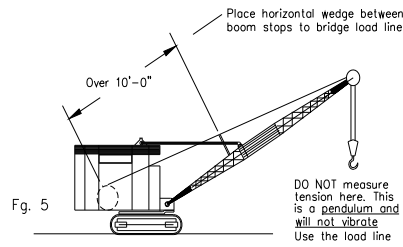
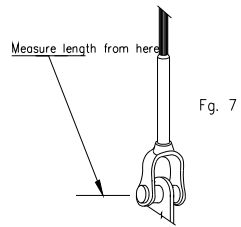
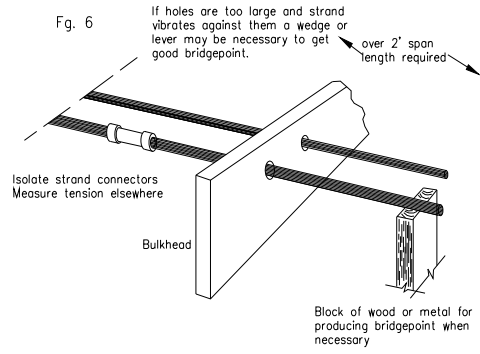

Fig. 5

IV. BRIDGEPOINTS IN PRESTRESSED CONCRETE

A few notes on prestress applications:

1. Bridging strand to strand – DON'T – it's unstable
2. Vibrations between bulkheads and strand – use a wedge.
3. Chuck joining strand in center of bridge length -- use another section to make the bridge.



THREE SIMPLE RULES FOR BRIDGING

About 99% of all the problems encountered (there are very few) in getting stable readings with DynaTension result from three oversights. They are listed below with their simple corrections.

1. Bridge Points Move: For DynaTension to operate, it is necessary that both ends of the bridge be completely stationary in space while only the rope vibrates. This is the most often ignored rule and can cause unsuccessful readings. It's easy to handle when you realize the requirement. Just make both ends stationary and good readings will be obtained every time.
2. Rope Rattles Against Bridge Points: It is not necessary to exert a lot of force to bridge a long span. The only requirement is that the bridge be firmly pressed against the rope at the bridge point. If wedges are necessary, use them.
3. Rope Rubs Against, Scrapes or Touches Another Object Between Bridge Points: The bridge or free span of rope must be completely free from ANY surrounding object. Even the rubber rain flaps found in the engine compartments of some cranes will, if they touch the part of the rope being tested, make unstable readings. Push them out of the way or use another section of rope. sometimes an obstruction can become a good bridging point with a little wedging.